

sc1000™ Multi-parameter Universal Controller

Controller—Multi-Parameter

Features and Benefits

Modular System

The Hach sc1000 Multi-parameter Universal Controller is a fully modular system consisting of a Display Module and one or more Probe Modules.

Probe Module—Each sc1000 Probe Module provides power to the system and can accept up to 8 digital sensors. Probe Modules can be networked together to accommodate many more sensors attached to the same network.

Display Module—The sc1000 Display Module is a full-featured controller with a large color touch-screen display. The intuitive, easy to use interface can be used for any number of parameters. One Display Module controls either a single Probe Module or a number of Probe Modules connected by a digital network. The Display Module is fully portable and can be disconnected and moved anywhere within the network.

“Plug and Play” Operation

There's no complicated wiring or set up procedures with the sc1000 controller. Just plug the sensor into a Probe Module and it's ready for use without special ordering or software configuration.

Mix and Match Digital Sensors

The digital sensors that can be plugged into the Probe Module can be any from Hach's line of digital sensors—dissolved oxygen, pH, ORP, conductivity, turbidity, suspended solids, nitrate, etc. Use them in any combination.

Flexible Communication Options

Communication and relay options for the sc1000 controller can be configured to suit any situation. Standard configurations for a single Probe Module include;

- up to 4 potential free relay contacts for alarm and control functions,
- up to 12 analog outputs for measured values,
- up to 12 digital or analog inputs from instruments (i.e., flow or pressure sensors),
- field bus card to integrate with an external network (MODBUS® and PROFIBUS DP are currently available).

Additional relays and analog inputs and outputs can be added by networking a second Probe Module or optional DIN-rail communication modules.



The Hach Model sc1000 Multi-parameter Universal Controller is a state-of-the-art modular controller system. Use it directly with 8 sensors or network several together to accommodate many more sensors and parameters. It is completely compatible with Hach's full range of digital sensors.

DW

WW

PW

IW

Digital Reliability and Integration

Digital signals between the sc1000 controller and attached sensors assure data integrity and immunity from signal interference. Digital outputs from the sc1000 make it easy to integrate the controller into an existing network. Additional advanced communication features include:

- Ethernet port (standard)—attach a computer directly to the sc1000 controller to operate the system from the computer. Download data logs and upload software updates.
- MultiMediaCard (MMC) slot (standard)—transfer data and software updates using a standard memory card like those used in digital cameras.
- GSM wireless modem (optional)—use it for fully remote operation of the sc1000 controller, including transfer of data and software updates. (FCC approval pending.)

Expandable and Upgradeable

The sc1000 controller can adapt to your needs. Change probes without changing the controller. Probe Modules can be added or removed depending on operational needs. Fully upgradeable software ensures that this system will not be obsolete.

DW = drinking water WW = wastewater municipal PW = pure water / power
IW = industrial water E = environmental C = collections FB = food and beverage

DASTEC S.R.L.

Distribuidores Autorizados

Buenos Aires, Argentina

Tel.: (54-11) 5352-2500

E mail: info@dastecsrl.com.ar

Web: www.dastecsrl.com.ar



Be Right™

Specifications*

Ambient Conditions

Operation: -20 to 55°C (-4 to 131°F);
0 to 95% relative humidity, non-condensing

Storage: -20 to 70°C (-4 to 158°F);
0 to 95% relative humidity, non-condensing

Power Requirements

100 to 230 Vac, 50/60 Hz

Power: 75 W

Optional: 24 Vdc

Display

1/4 VGA graphical backlit TFT color touch screen

Resolution: 320 x 240 pixels

Relays

Up to four SPDT, user-configurable contacts rated 100 to 230 Vac, 5 Amp resistive maximum, per probe module. Additional relays are available via digital network connection.

Outputs

Up to 12 analog 0/4-20 mA, maximum impedance 500 Ohms per probe module.

Additional analog outputs are available via digital network connection.

Optional digital communications via MODBUS® (RS-485) or PROFIBUS DP.

Inputs

Up to 12 analog 0-20 mA, maximum impedance 500 Ohms per probe module.

Additional inputs are available via digital network connection.

Control

PID, high/low phasing, setpoint, deadband, overfeed timer, off delay, and on delay

Alarms

Low alarm point, low alarm point deadband, high alarm point, high alarm point deadband, off delay, and on delay

Communication (Optional)

MODBUS® (RS-485): Advanced communications/networking with PLC or SCADA system directly from analyzer.

PROFIBUS DP

GSM cellular module (FCC approval pending.)

Ethernet service port (standard)

Multimedia memory card slot (standard)

Memory Backup

All user settings are retained indefinitely in memory (non-volatile) (EEPROM)

Mounting Configurations

Surface, panel, and pipe (horizontal and vertical)

Enclosure

IP65; ABS (display module) and metal (probe module) enclosure with corrosion-resistant finish

Dimensions

Probe module with attached display module:
315 x 250 x 142 mm (12.4 x 9.8 x 5.6 in.)

Weight

Approximately 6.5 kg (14.3 lbs.) depending on configuration

Certifications

cTUVus to UL 61010A-1 and CSA C22.2 No. 1010.1
TUV-GS to EN 61010-1
CE per 73/23/EEC and 89/336/EEC

*Specifications subject to change without notice.

Engineering Specifications

- The controller shall consist of a portable display module connected to one or more probe modules.
- The portable display module shall have a color graphical touch-screen display.
- Connections between the sensors and the controller shall be "plug and play."
- The controller shall have the option for MODBUS or PROFIBUS DP communication.
- The interface unit shall allow operators to control sensor and interface functions with menu-driven software.
- The controller shall have up to four potential free relays, four analog outputs and four analog inputs per probe module (all expandable via the controllers internal network).
- The controller shall have an Ethernet service port for direct connection to a personal computer for transfer of data and software updates.
- The controller shall have a Multimedia card slot for transfer of data and software updates.
- The controller shall be housed in an IP65 enclosure.
- The controller shall be mounted horizontally or vertically on surface or pipe.
- The AC power supply shall be housed in the interface unit and automatically accept input in the range of 100 to 230 Vac, 50/60 Hz. An internal 24 Vdc power supply shall be available as an option.
- All system components shall be certified by cTUVus to UL 61010A-1 and CSA C22.2 No. 1010.1; TUV-GS to EN 61010-1; CE per 73/23/EEC and 89/336/EEC.
- The controller shall be warranted for 12 months against defects in material and workmanship.
- The controller shall be Hach Company Model sc1000 Multi-parameter Universal Controller.

Dimensions

The sc1000 controller unit can be installed on a pole, wall, or a floor stand. No tools are needed to connect the controller unit to any Hach digital sensor.

Front View

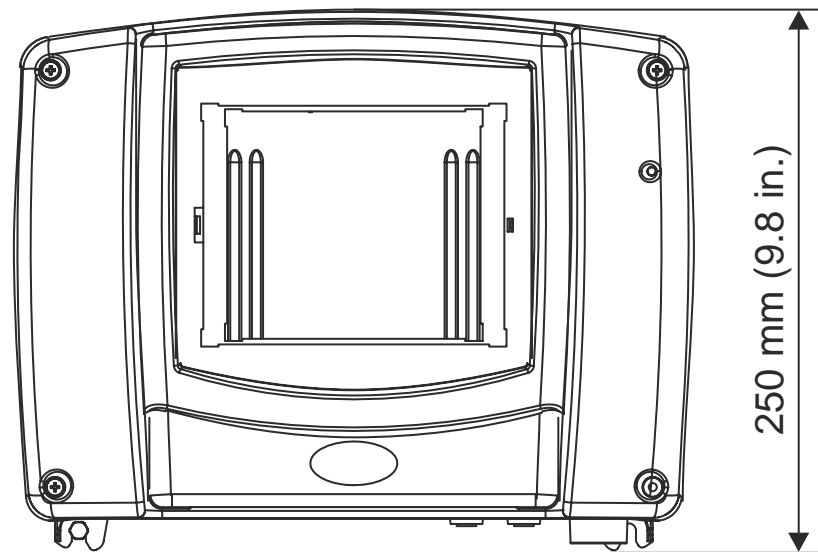

Bottom View

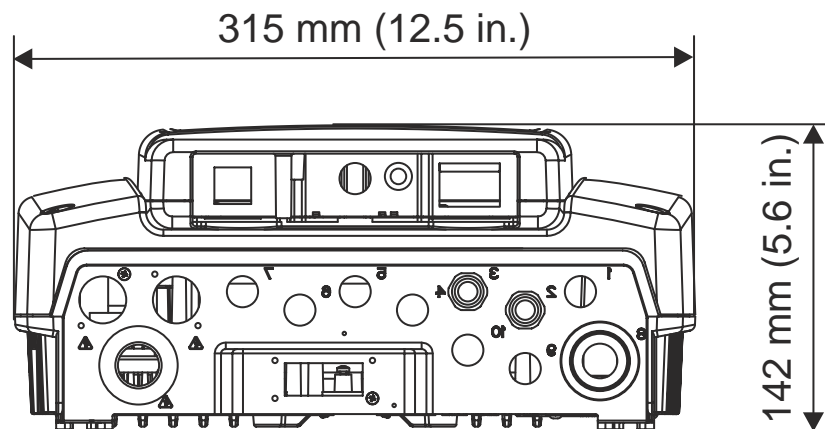

Ordering Information

- LXV402.99.00002** sc1000 Display Module
- LXV400.99.1R572** sc1000 Probe Module, 4 sensors, 4 mA Out, 4 mA In, 4 Relays, 110-230V
- LXV400.99.1B572** sc1000 Probe Module, 4 sensors, 4 mA Out, 4 mA In, 4 Relays, RS-485 (MODBUS), 110-230V
- LXV400.99.1F572** sc1000 Probe Module, 4 sensors, 4 mA Out, 4 mA In, 4 Relays, PROFIBUS DP, 110-230V
- LXV400.99.1R582** sc1000 Probe Module, 6 sensors, 4 mA Out, 4 mA In, 4 Relays, 110-230V

Additional combinations are available. Contact your Hach representative or call 1-800-227-4224 for more information.

Power Cords

- 54488-00** Power Cord with strain relief, 125 Vac, American-style plug
- 54489-00** Power Cord with strain relief, 230 Vac, European-style plug

Accessories

- LZX958** Sun Shield, for sc1000 controller
- LZX918** sc1000 internal network connector
- LZX988** sc1000 internal network cable, 100 m (328 ft.)
- LZX989** sc1000 internal network cable, 500 m (1640 ft.)

To complete your digital measurement system, choose from Hach's family of digital products...



sc100™ Controller

Plug-and-play, mix-and-match operation for one or two sensors (see Lit. # 2463)

Hach LDO™ Dissolved Oxygen Probe

Break-through luminescent technology for dissolved oxygen (see Lit. # 2455)

Model 5740 sc Galvanic Membrane Dissolved Oxygen Sensor

Replaceable membrane cartridge for simple maintenance (see Lit. # 2469)

Differential pH and ORP Sensors

Three electrodes for increased measurement accuracy (see Lit. # 2467)

3/4-inch Combination pH and ORP Sensor Kits

Designed specifically for immersion or in-line mounting (see Lit. # 2470)

Inductive Conductivity Sensors

Innovative technology for harsh environments (see Lit. # 2465)

Contacting Conductivity Sensors

Enhanced performance sensors for a variety of applications (see Lit. # 2468)

1720E Low Range Turbidimeter

Meets performance criteria established by the USEPA for regulatory reporting (see Lit. # 2457)

SOLITAX® sc Turbidity and Suspended Solids Sensors

Accurate, color-independent measurement in any application (see Lit. # 2472)

NITRATAX™ UV Nitrate Sensors

Simple and accurate technology for low cost of operation (see Lit. # 2464)

At Hach, it's about learning from our customers and providing the right answers. It's more than ensuring the quality of water—it's about ensuring the quality of life. When it comes to the things that touch our lives...

Keep it pure.

Make it simple.

Be right.

For current price information, technical support, and ordering assistance, contact the Hach office or distributor serving your area.

In the United States, contact:

HACH COMPANY World Headquarters
P.O. Box 389
Loveland, Colorado 80539-0389
U.S.A.
Telephone: 800-227-4224
Fax: 970-669-2932
E-mail: orders@hach.com
www.hach.com

U.S. exporters and customers in Canada, Latin America, sub-Saharan Africa, Asia, and Australia/New Zealand, contact:

HACH COMPANY World Headquarters
P.O. Box 389
Loveland, Colorado 80539-0389
U.S.A.
Telephone: 970-669-3050
Fax: 970-461-3939
E-mail: intl@hach.com
www.hach.com

In Europe, the Middle East, and Mediterranean Africa, contact:

HACH + LANGE Europe
Dr. Bruno Lange GmbH & Co. KG
Willstätterstraße 11
D-40549 Düsseldorf
GERMANY
Tel: +49 (0) 211 5288-0
Fax: +49 (0) 211 5288-143
E-mail: info@hach-lange.de
www.hach-lange.com

Lit. No. 2403

B53 Printed in U.S.A.

©Hach Company, 2005. All rights reserved.

In the interest of improving and updating its equipment, Hach Company reserves the right to alter specifications to equipment at any time.

DASTEC S.R.L.

Distribuidores Autorizados

Buenos Aires, Argentina

Tel.: (54-11) 5352-2500

E mail: info@dastecsrl.com.ar

Web: www.dastecsrl.com.ar



Be Right™